

SECTION Y-Y

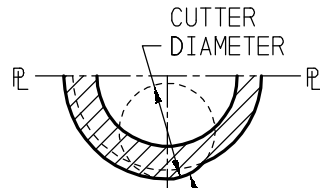

START AND STOP OF
THREAD TO CONFORM
TO CUTTER RADIUS

SECTION X-X

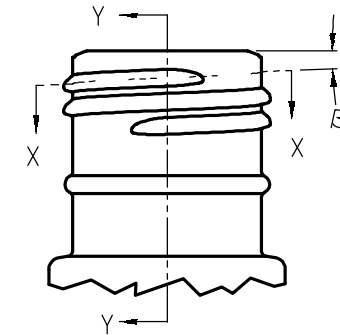
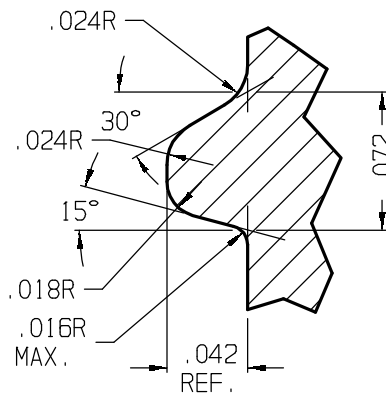

10 T.P.I.

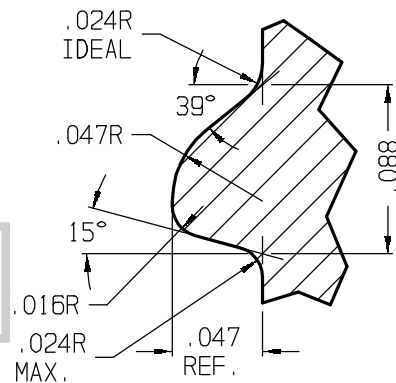

8 T.P.I.
THREAD CROSS SECTIONS

SIZE	T	E	S	H	I	L	W	B	CUT. DIA.	T.P.I.
					MIN.	MIN.	APPR.			
20	0.773 ±.010	0.689 ±.010	0.095 ±.010	0.732 ^{+.013} / _{-.012}	0.404	0.440	0.078	2° 30'	0.375	10
22	0.852 ±.010	0.768 ±.010	0.095 ±.010	0.827 ^{+.013} / _{-.012}	0.483	0.530	0.078	2° 15'	0.375	10
24	0.930 ±.010	0.846 ±.010	0.095 ±.010	0.947 ^{+.013} / _{-.012}	0.516	0.545	0.078	2° 3'	0.375	10
28	1.076 ^{+.012} / _{-.013}	0.982 ^{+.012} / _{-.013}	0.095 ±.010	1.072 ^{+.013} / _{-.012}	0.680	0.639	0.094	2° 13'	0.500	8

- 'H' DIMENSION REPRESENTS DISTANCE FROM TOP OF FINISH DOWN TO POINT WHERE LINE TANGENT TO 'T' INTERSECTS TOP OF SHOULDER. WHEN SHOULDER IS FORMED IN THE BLOW MOLD 'H' DIMENSION PLUS TOLERANCE IS INCREASED BY .015.
- B = HELIX ANGLE OR ANGLE OF FIXTURE TO CUTTER.
- TANGENT B = $\frac{\text{PITCH}}{\pi (\text{MEAN BETWEEN MEAN 'T' AND MEAN 'E'})}$
- A MINIMUM OF TWO TURNS OF THREAD SHOULD BE MAINTAINED, WITH FULL PROJECTION EXCEPT WHEN DEPRESSED OR INTERRUPTED AT MOLD SEAMS. REFER TO GLASS FINISH NO. 405 FOR DEPRESSED THREAD DETAIL.
- CONTOUR OF BEAD IS OPTIONAL PROVIDED THE DIAMETER AND 'W' ARE ADHERED TO.
- 'I' DIMENSION IS MEASURED THROUGH FULL LENGTH OF FINISH.
- THIS FINISH TO BE MADE SMOOTH TOP CONSTRUCTION.

THIS OFFICIAL GLASS PACKAGING INSTITUTE PRINT CONSTITUTES ONE IN A SERIES OF VOLUNTARY STANDARDS INTENDED TO PROVIDE A BASIS FOR ACHIEVING COMPATIBILITY AND INTERCHANGEABILITY BETWEEN MANUFACTURERS AND USERS OF GLASS CONTAINERS AND CLOSURES THEREFOR. THE USER SHOULD BE AWARE THAT OTHER CONTAINER AND CLOSURE DESIGNS MAY DIFFER FROM THIS VOLUNTARY STANDARD, AND IT IS THE USER'S RESPONSIBILITY TO MAKE THE FINAL DETERMINATION AS TO DESIGN AND COMPATIBILITY. GPI ASSUMES NO RESPONSIBILITY FOR EITHER THE USE OF OR INTERPRETATION OF THE STANDARD, FOR IT BEING CURRENT, OR FOR THE DETERMINATION WHETHER ANY PARTICULAR MANUFACTURER'S PRODUCT CONFORMS TO THE STANDARD. THIS DRAWING CONTAINS INFORMATION TAKEN FROM ONE OR MORE PRINTS OF THE GLASS PACKAGING INSTITUTE (GPI). GPI OWNS ALL RIGHT, TITLE AND INTEREST IN THE COPYRIGHTS TO THIS DRAWING AND TO THESE PRINTS. GPI REQUIRES THAT YOU NOT REPRODUCE THIS DRAWING FOR OR DISTRIBUTE THIS DRAWING TO ANY THIRD PARTY WITHOUT GPI'S WRITTEN CONSENT. ANY INQUIRIES OR SUGGESTIONS CONCERNING THIS STANDARD CAN BE ADDRESSED TO THE GLASS PACKAGING INSTITUTE, WASHINGTON D.C. AT WWW.GPI.ORG.

COPYRIGHT © GPI 1995, 1999, 2001

Edward Grant CHAIRMAN	PRINTED AND DISTRIBUTED AS A VOLUNTARY STANDARD BY GLASS PACKAGING INSTITUTE COMMITTEE ON DESIGN AND SPECIFICATIONS	APPROVED FOR PUBLICATION 6-21-01	SUPERSEDES DWG. NO. 4224
GLASS FINISH NUMBER 422		GPI DWG. NO.	
CONTINUOUS THREAD FINISH FOR POLYPROPYLENE LINERLESS CLOSURE		4225	